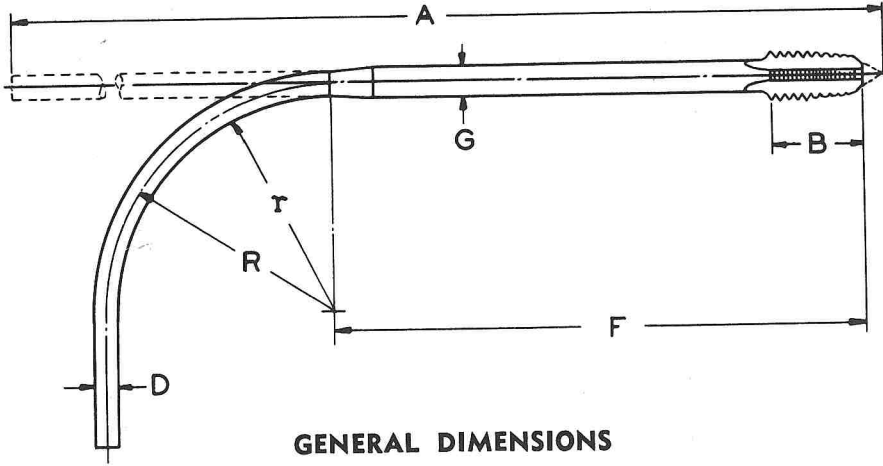

Table 36

BENT SHANK TAPPER TAPS

Fractional Sizes



GENERAL DIMENSIONS

Diam. of Tap Inches	Size of Machine Inch.	THREADS PER INCH				No. of Flutes	DIMENSIONS — INCHES						
		N. C.	N. F.	N. S.	S. B.		A	B	D	F	G	R	r
3/32	3/16	28	3	47/8	7/16	.128	27/16	..	13/16	1.124
3/16	3/16	24	3	427/32	1/2	.153	213/32	..	13/16	1.111
1/8	1/4	40	..	3	67/16	5/16	.093	323/32	..	1 1/4	1.204
5/32	1/4	28	3	67/16	7/16	.128	3 3/4	..	1 1/4	1.186
3/16	1/4	24	..	3	613/32	1/2	.133	323/32	..	1 1/4	1.183
3/16	1/4	32	..	3	613/32	3/8	.147	323/32	..	1 1/4	1.176
3/16	1/4	24	3	613/32	1/2	.153	323/32	..	1 1/4	1.174
1/4	1/4	20	3	63/8	21/32	.180	323/32	..	1 1/4	1.160
1/4	1/4	..	28	3	63/8	5/8	.194	321/32	..	1 1/4	1.153
1/4	1/4	18	3	63/8	11/16	.200	323/32	..	1 1/4	1.150
3/16	1/4	18	3	611/32	11/16	.235	313/32	..	1 1/4	1.133
5/16	1/4	..	24	3	611/32	5/8	.245	313/32	..	1 1/4	1.128
1/4	3/8	20	3	85/8	21/32	.180	417/32	..	1 7/8	1.785
1/4	3/8	..	28	3	85/8	5/8	.194	417/32	..	1 7/8	1.778
5/16	3/8	18	3	811/32	3/4	.235	415/32	..	1 7/8	1.757
5/16	3/8	..	24	3	811/32	3/4	.245	415/32	..	1 7/8	1.752
3/8	3/8	16	3	83/8	13/16	.289	47/16	..	1 7/8	1.730
3/8	3/8	..	24	3	811/32	3/4	.289	43/8	.321	1 7/8	1.730
3/8	1/2	16	3	1111/16	13/16	.289	515/16	..	2 1/2	2.355
3/8	1/2	..	24	3	1123/32	3/4	.289	57/8	.321	2 1/2	2.355
7/16	1/2	14	3	12	13/16	.340	63/32	..	2 1/2	2.330
7/16	1/2	..	20	3	12	11/16	.340	63/32	.373	2 1/2	2.330
1/2	1/2	13	3	12	13/16	.395	67/16	..	2 1/2	2.302
1/2	1/2	..	20	3	12	11/16	.395	67/16	.435	2 1/2	2.302
9/16	5/8	12	3	15	13/16	.449	73/32	..	3 1/4	3.525
9/16	5/8	..	18	3	15	13/16	.449	73/32	.490	3 1/4	3.525
5/8	5/8	11	3	15	15/8	.502	71/4	..	3 1/4	3.499
5/8	5/8	..	18	3	15	13/16	.502	71/4	.553	3 1/4	3.499
3/4	5/8	10	3	15	113/16	.605	73/16	..	3 1/4	3.447
3/4	5/8	..	16	3	15	15/8	.605	73/16	.669	3 1/4	3.447
3/4	7/8	10	3	187/16	113/16	.605	81/2	..	4 1/2	4.197
3/4	7/8	..	16	3	187/16	15/8	.605	81/2	.669	4 1/2	4.197
7/8	7/8	9	3	187/16	113/16	.716	813/32	..	4 1/2	4.142
7/8	7/8	..	14	3	187/16	1 3/4	.716	813/32	.782	4 1/2	4.142
1	7/8	8	3	187/16	23/16	.823	813/32	..	4 1/2	4.088
1	7/8	..	12	3	187/16	2	.823	813/32	.892	4 1/2	4.088
1	7/8	14	..	3	187/16	1 3/4	.823	813/32	.907	4 1/2	4.088

* Recommended only for thin nuts.

NOTE: Solid or sectional type taps can be supplied for all type machines.