

# RITE ANGLE ATTACHMENTS

## R8 RITE ANGLE ATTACHMENT

### FEATURES:

- Suitable for most milling machines.
- Converts your vertical mill to a horizontal mill.
- Designed to simplify right angle work by reducing the need for special tooling and complex fixtures.
- For use on your R8 spindle with 3-3/8" overall diameter.
- Includes drawbar extension socket.

### STUB ARBOR



### R8 ARBOR 1"



### RITE ANGLE HEAD

Designed to simplify right angle work by reducing the need for special tooling and difficult fixtures. Ideal for cavities and pocket jobs. It has aligning pads (for R8 spindle).



### ARBOR SUPPORT

For use with rite angle attachment and mill arbor needle bearings support.



### 3 PC. SET Model 2564 2810

**\$698.00**

Wt. 58 lbs.

INCLUDES: Rite angle head, arbor support & R8 arbor 1".

### STUB ARBOR Model 2564 2804

**\$769.00**

Wt. 2.55 lbs.

### R8 ARBOR 1" Model 2564 2802

**\$1290.00**

Wt. 11.2 lbs.  
For use with rite angle attachment.

### RITE ANGLE HEAD Model 2564 2800

**\$498.00**

Wt. 25 lbs.

### ARBOR SUPPORT Model 2564 2801

**\$1290.00**

Wt. 21.8 lbs.

## PRESTIGE™ STEEL BODY R8 RITE ANGLE ATTACHMENT



### FEATURES:

- All steel body.
- Ribbed support.
- Alignment flats on two sides.
- Grease zerk.
- Precision hardened and ground spiral bevel gears.
- Packed in molybdenum grease.
- 1.33 to 1 gear ratio.
- R8 collet spindle.



### R8 ARBOR 1" Model 2564 2852

**\$472.50**

Wt. 5.7 lbs.

### ARBOR SUPPORT Model 2564 2851

**\$519.75**

Wt. 21 lbs.

### RITE ANGLE HEAD Model 2564 2850

**\$838.95**

Wt. 20.8 lbs.

### 3 PC. SET Model 5000 1900

**\$1,739.64**

Wt. 47.5 lbs.

INCLUDES: R8 arbor, 1" arbor support & rite angle head.

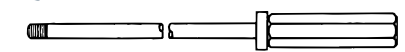

### SPECIAL DRAWBAR With Extended Hex for Bridgeport/Kondia

With 7/16-20 thread 4140 heat-treated alloy steel.

### Model 2564 2950

**\$357.50**

Note: A special drawbar is required with rite angle head.

## ANGLE HEADS

### RIGHT ANGLE HEAD INTEGRAL SHANK

The GS integral shank style right angle head is designed for use with CNC type machines with automatic tool changing capabilities.

#### PVI FEATURES:

- 90° pivoting cutter spindle.
- Includes storage case.
- Uses ER Collets.

#### FXI FEATURES:

- Body can be rotated a full 360°.
- One piece construction ensures maximum rigidity.
- Includes storage case.
- Uses ER Collets.



PVI Angle Head with Case.

### PVI Integral

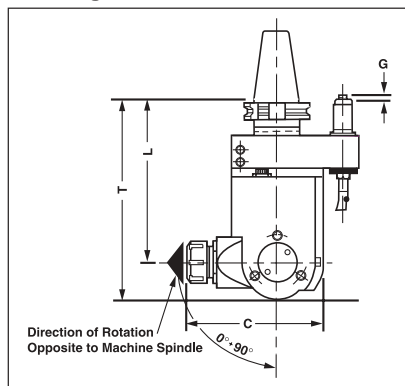

	Model FXI ER-25	Model FXI ER-32	Model PVI ER-25	Model PVI ER-32
C	110	146	137	155
T	179	197	183.5	201
G	90	110	90	110
L	150	160	150	160
RPM Max.	4,000	4,000	4,000	4,000
Weight (kg.)	7.5	11	8.5	13

### PIVOTING (PVI)

Model	Taper	Description	Collet	Capacity	Price
5200 1800	CAT 40	PVI	ER25	1-16mm	<b>5,346.00</b>
5200 1805	CAT 50	PVI	ER32	2-20mm	<b>5,733.00</b>
5200 1810	BT40	PVI	ER25	1-16mm	<b>5,346.00</b>

### FIXED 90° (FXI)

Model	Taper	Description	Collet	Capacity	Price
5200 1840	CAT 40	FXI	ER25	1-16mm	<b>4,410.00</b>
5200 1845	CAT 50	FXI	ER32	2-20mm	<b>4,707.00</b>
5200 1850	BT40	FXI	ER25	1-16mm	<b>4,410.00</b>

### FEATURES:

- Allows 360° rotating head.
- 90° pivoting cutter spindle.
- Two piece construction allows different drive tapers to be used. Does not limit this head to one specific machine.

Model ER-32	
C	155
H	32
V	133
RPM Max.	4,000

### MODULAR PIVOTING (PVM)

Model	Taper	Description	Collet	Capacity	Price
5200 1880	ISO 50	PVM	ER32	2-20mm	<b>7,015.00</b>

### 15 PC. ER 25 COLLET SET 3/64-5/8"

Model 2537 0329 ..... **\$414.39** E

### 18 PC. ER 32 COLLET SET 7/64-25/32"

Model 2491 0198 ..... **\$508.60** E

### PVM ER-32

